

High-Speed and High-Precision SCARA Robot

TH550A

Robot Specifications



Model	TH550A	
Type	Horizontal multi-joint	
Number of axis	4	
Arm length	550mm(300mm+250mm)	
Working envelope	Axis 1	±120°
	Axis 2	±145°
	Axis 3(Z-axis)	0~150mm
	Axis 4(Z-axis rotation)	±360°
Maximum speed	Axis 1	375°/s
	Axis 2	600°/s
	Axis 3(Z-axis)	2000mm/s
	Axis 4(Z-axis rotation)	2000°/s
	Composite	6.2m/s
Standard cycle time(with 1kg load)	0.30sec.	
Maximum payload mass	5kg	
Allowable moment of inertia	0.06kg·m ²	
Positioning repeatability	X-Y	±0.01mm
	Axis 3(Z-axis)	±0.01mm
	Axis 4(Z-axis rotation)	±0.005°
Hand wiring	8 inputs/8 outputs	
Hand piping	φ4×4pcs	
Position Detection	Absolute Encoders	
Robot controller cable	5m (optional:Max. 25m)	
Mass	26kg	
Noise level	<72dB(A)	
Options	Wash-down Design(IP65), Ceiling-mount type, Cleanroom Design, Z-axis long stroke,Z-axis Cap	

Controller Specifications



Controller
TS3000

Model	TS3000	
Number of axis	Standard 4 axis(Maximum 5 axes)	
Operation mode	PTP,CP (linear,Circular),Short-cut,Arch motion	
Storage Capacity	Approx. Total:12800points+25600steps	
	1 program:2000points+3000steps	
Number of programs	Maximum256(247 user files+9 system files)	
Programming Language	SCOL(similar to BASIC)	
Teaching Unit	Teach pendant TP1000:Cable length 5m (Programing support PC software TSPC also available)	
External I/O Signals	32 inputs/32 outputs	
Hand Control Signals	8/8 can be assigned to system signals.	
External Operation Signal	Input:cycle operation mode,start,stop,program reset,etc. Output:Servo ON,operation ready,fault,etc.	
Serial communication port	RS232C:2ports (HOST,COM1) , Ethernet 1port	
Other Functions	Torque control, interrupt function, self diagnosis, I/O control, communication during motion, coordinate calculations, built-in PLC, conveyor synchronisation etc.	
Power Supply	Single phase, AC200V~240V 50/60Hz	
Power capacity	2.3kVA	
Outer Dimensions and Mass	290 (W) ×230 (H) ×298 (D) [mm], 13kg	
PC Software for Programming Support(Optional)	TSPC:Program editor,teaching,remote operation TCPRGOS:PLC sequence program creation	
Options	I/Oextension,I/Ocables, Field-Network(CC-Link,DeviceNet,Profibus)	
Memory	USB memory	

TEACH PENDANT(OPTION)

TH550A [External View]

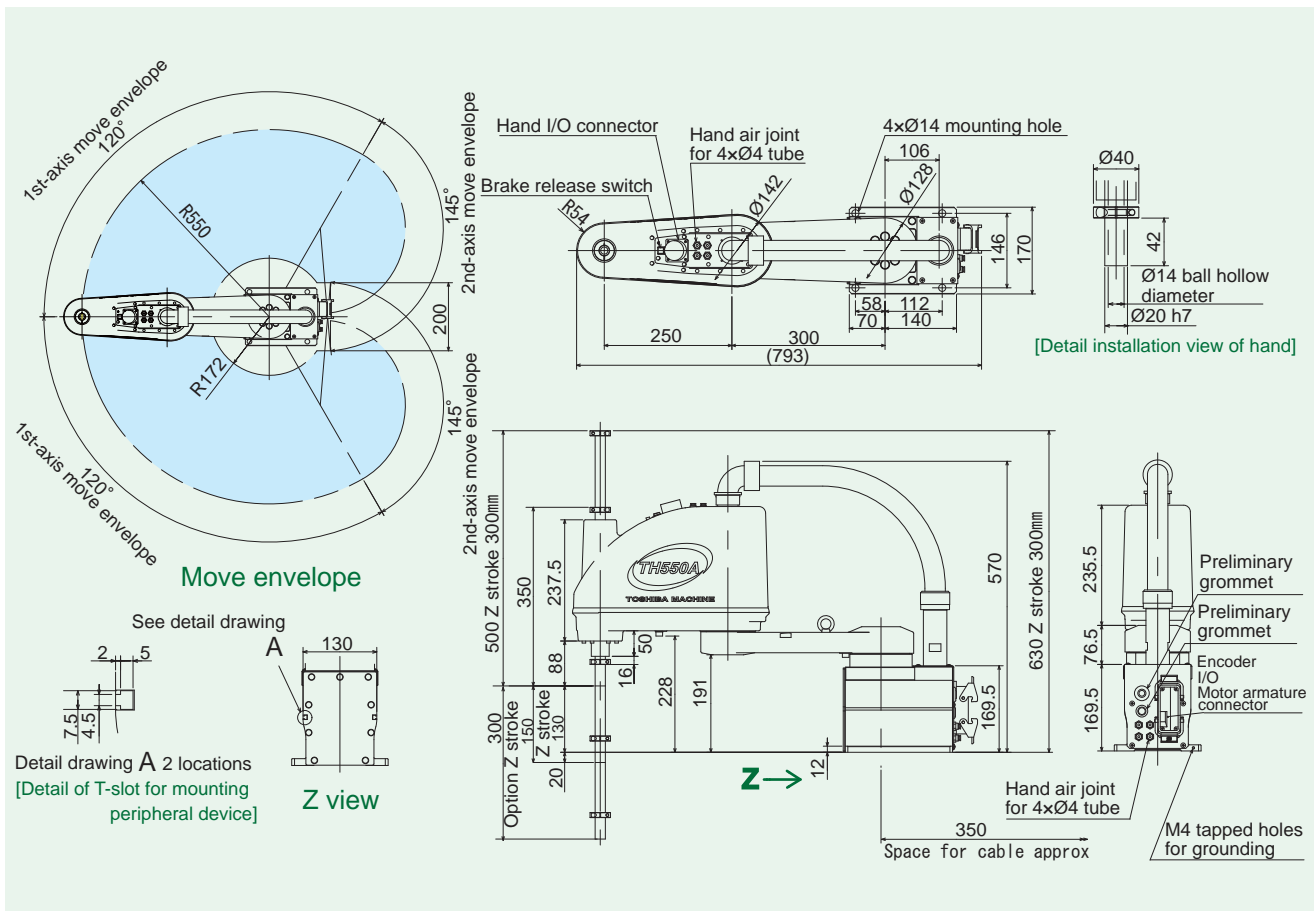

TS3000 [External View]

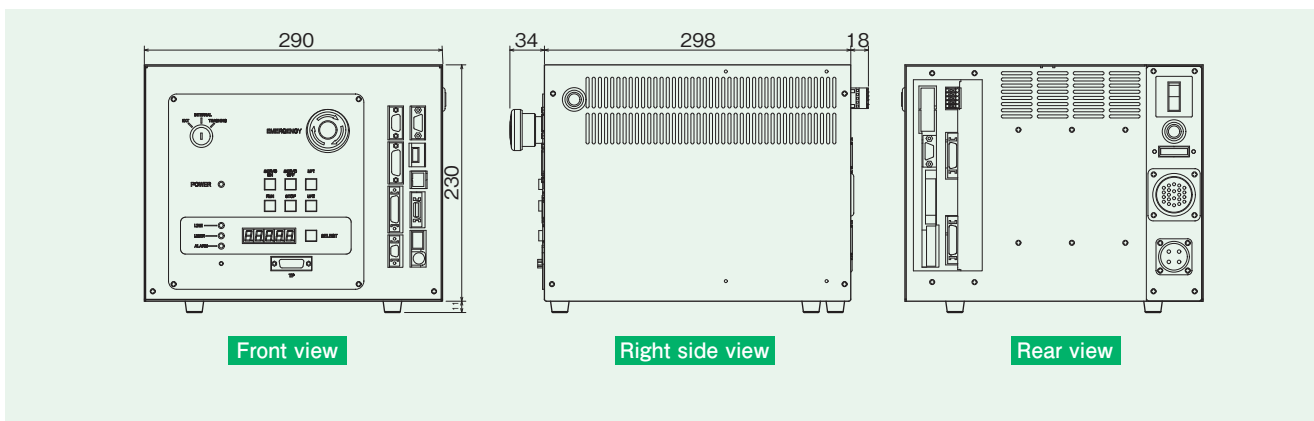

TOSHIBA MACHINE CO.,LTD. HEAD OFFICE
 Control Systems Sales Department, Control Systems Division
 2068-3, Ooka, Numazu-shi, Shizuoka-ken 410-8510, Japan
 TEL:[81]-(0)55-926-5032 FAX:[81]-(0)55-925-6527

TOSHIBA MACHINE CO.,AMERICA.
 755 Greenleaf Avenue, EIK Grove Village, IL 60007, U.S.A.
 TEL:[1]-847-593-1616 FAX:[1]-847-593-0897

TM ROBOTICS(EUROPE) LTD.
 Unit 2, Bridge Gate Center, Martinfield,
 Welwyn Garden City, Herts, AL7 1JG,UK
 TEL [44]-(0)1707-290370 FAX [44]-(0)1707-376662

URL:<http://www.toshiba-machine.co.jp/seiji/prod/sr>
http://www.toshiba-machine.com/robotics/SR_homepagef.htm
<http://www.tmrobotics.co.uk>



Caution

Before operating the industrial robot, read through and completely understand the instruction manuals.

■ The contents included in this catalog are subject to change without prior notice to reflect improvements.