

TOSHIBA MACHINE

TOSHIBA MACHINE SCARA robot series
NEW LITE models THL Series

THL 700

- **Low cost**
Excellent performance at affordable prices.
- **Light weight**
Up to 50% lighter than our previous models.
Capable of reducing environmental impact.
- **Energy-efficient**
Up to 50% reduction in required power-supply capacity compared with our previous models.
Low-power consumption robots ideal for energy conservation era.

Robot Specifications



Model	THL700	
Type	Horizontal multi-joint	
No. of controlled axes	4	
Arm length	700mm (400mm+300mm)	
Working envelope	Axis 1	±125°
	Axis 2	±145°
	Axis 3 (Z-axis)	0~150mm [Option:300mm]
	Axis 4 (Z-axis rotation)	±360°
Maximum speed	Axis 1	450°/s
	Axis 2	450°/s
	Axis 3 (Z-axis)	2000mm/s
	Axis 4 (Z-axis rotation)	1700°/s
	Composite	7.9m/s
Cycle time (with 2kg load) *2	0,50s	
Maximum payload mass	10kg [Ratings:2kg]	
Allowable moment of inertia	0.2kg·m ²	
Positioning repeatability *3	X-Y	±0,01mm
	Z (Axis 3)	±0,015mm
	Axis θ (Z-axis rotation)	±0,007°
Hand wiring	8 inputs/8 outputs	
Hand pneumatic joints *4	φ6 ×3 pcs	
Position detection	Absolute	
Robot controller cable	3,5m	
Mass	24kg	

*1 : Acceleration/deceleration rates may be limited according to the motion pattern, load mass and amount of offset.

*2 : When the environment temperature is constant 20°C. Positioning repeatability accuracy in one-direction movement. Not absolute positioning accuracy.

*3 : Horizontal 300mm, vertical 25mm, round-trip. Continuous operation is not possible beyond the effective load ratio.

*4 : Pneumatic joints are provided on the base. Please refer to the drawings for the details of the pneumatic joints. Pipes to be provided by the customers.

Controller Specifications



Controller
TS3000

Model	TS3000	
Number of axis	Standard 4 axis (Maximum 5 axis)	
Operation mode	PTP, CP (Linear, Circular), Short-cut, Arch motion	
Storage capacity	Approx. Total:12800points+25600steps	
	1 program:2000points+3000steps	
Number of programs	Maximum 256 (247 user files+9 system files)	
Programming language	SCOL (similar to BASIC)	
Teaching unit	Teach pendant TP1000:Cable length 5m (Programming support PC software TSPC also available)	
External I/O signals	32 inputs/32 outputs	
Hand control signals	8/8 can be assigned to system signals.	
External operation signal	Input:cycle operation mode, start, stop, program reset, etc Output:Servo ON, operation ready, fault, etc	
Serial communication port	RS232C:2ports (HOST, COM1), Ethernet 1port *5	
Other functions	Torque control, interrupt function, self diagnosis, I/O control, communication during motion, coordinate calculations, built-in PLC, conveyor synchronisation etc.	
Power supply	Single phase, AC200V~240V 50/60Hz	
Power capacity	1,4kVA	
Outer Dimensions and Mass	290 (W)×230 (H)×298 (D) [mm], 1,3kg	
PC Software for Programming Support (Option)	TSPC:Program editor, teaching, remote operation TCPRGOS:PLC sequence program creation	
Options	I/Oextension, I/Ocables, Field-Network (CC-Link, DeviceNet, Profibus) *5	
External memory	USB memory stick	

TEACH PENDANT(OPTION)

*5:Ethernet is a registered trademark of XEROX Corp. in the U.S.A.
CC-Link is a registered trademark of CC-Link Partner Association.
DeviceNet is a registered trademark of ODVA.
Profibus is a registered trademark of Profibus User Organization.

THL700Q External View]

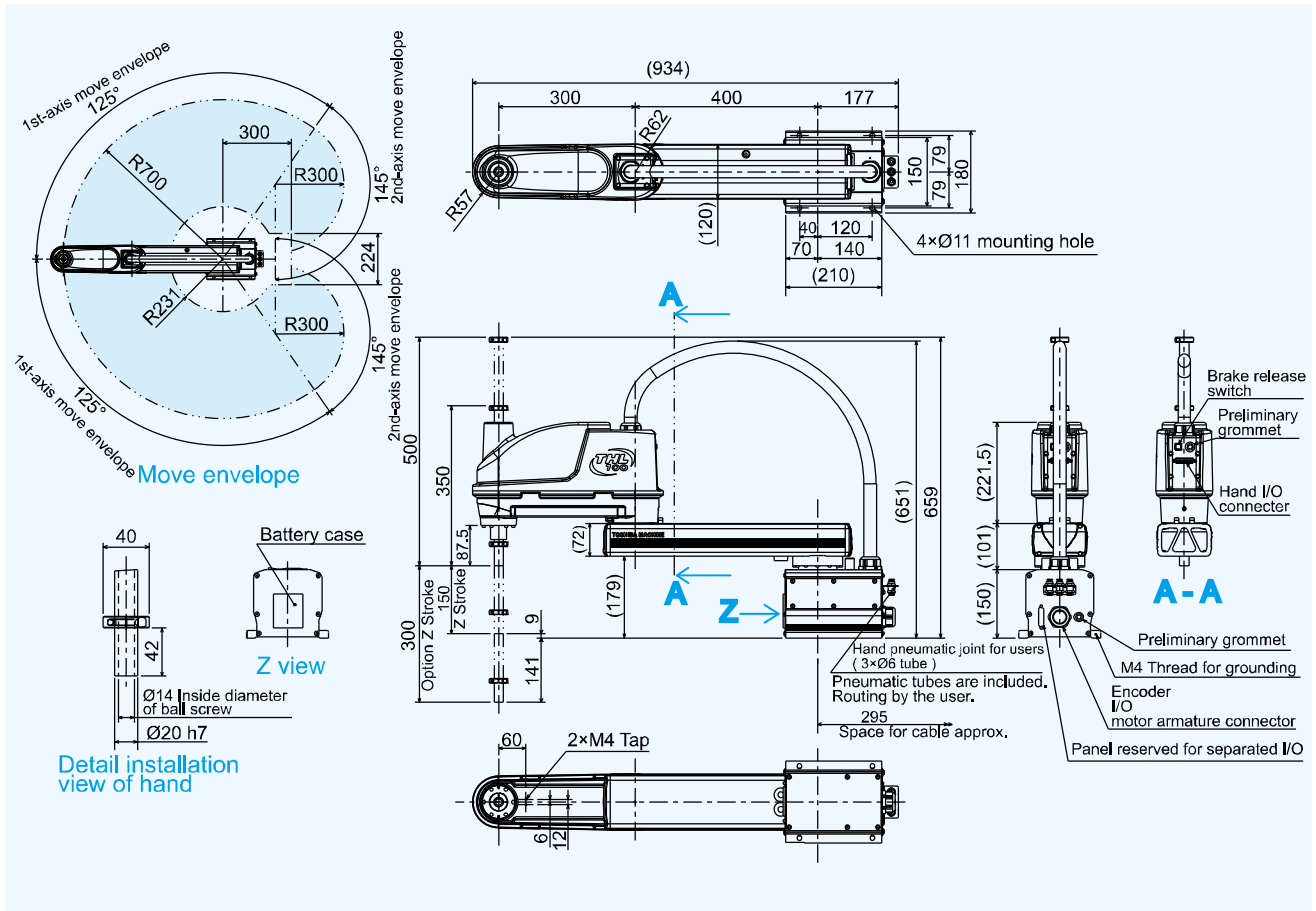

TS300Q External View]

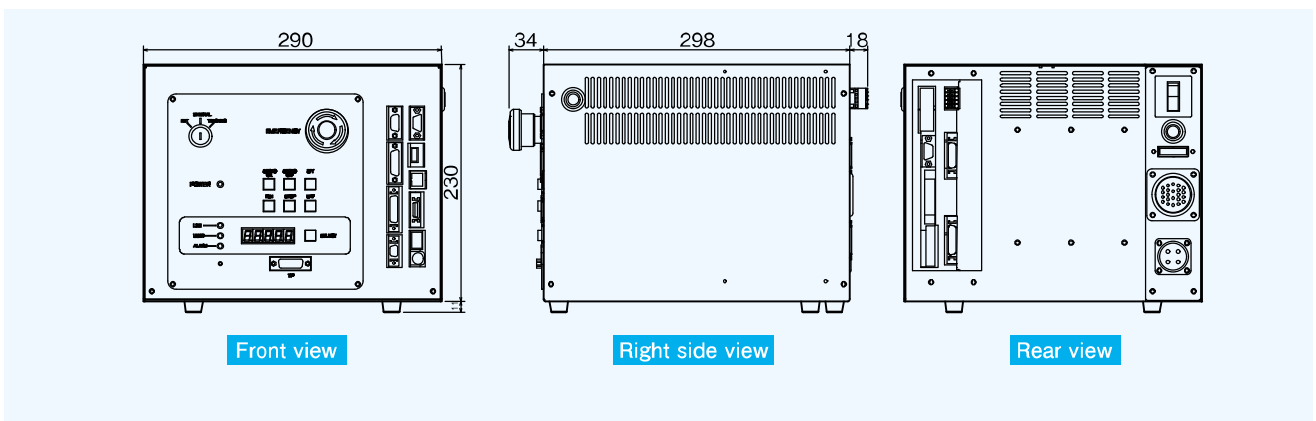

TOSHIBA MACHINE CO.,LTD. HEAD OFFICE
Control Systems Sales Department, Control Systems Division
2068-3, Ooka, Numazu-shi, Shizuoka-ken 410-8510, Japan
TEL:[81]-055-926-5032 FAX:[81]-055-925-6527

TOSHIBA MACHINE CO.,AMERICA.
755 Greenleaf Avenue, Elk Grove Village, IL 60007, U.S.A.
TEL:[1]-847-593-1616 FAX:[1]-847-593-0897

TM ROBOTICS (EUROPE) LTD.
Unit 2, Bridge Gate Centre, Martinfield,
Welwyn Garden City, Herts AL7 1JG, UK
TEL [44]-01707-290370 FAX [44]-01707-376662

URL:<http://www.toshiba-machine.co.jp/en/product/robot/index.html>
<http://www.toshiba-machine.com>
<http://www.tmrobotics.co.uk>



Before operating the industrial robot, read through and completely understand the instruction manuals.

■ The contents included in this catalog are subject to change without prior notice to reflect improvements.