

TOSHIBA MACHINE

Vertically Articulated Robot



New release of TVL700
in addition to TVL500



TVL700

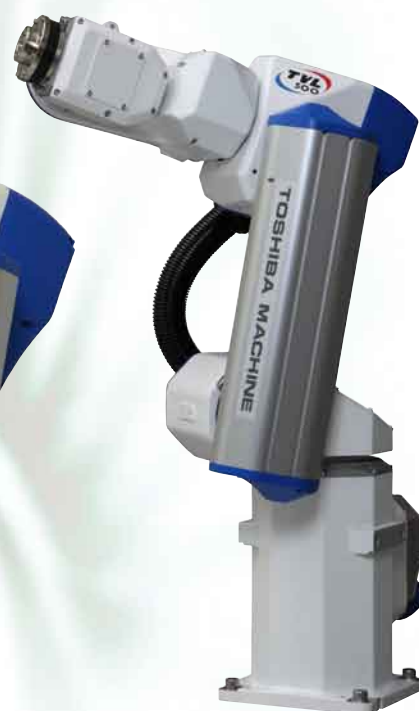

TVL500

Expansion of the range offering high productivity
in assembly and pick-and-place applications.

[Specifications]

Model	TVL700	
Type	Vertically articulated robot	
Number of controlled axis	6	
Arm length	Total length	700mm
	1st arm	400mm
	2nd arm	300mm
Working envelope	Reach	801mm
	Axis 1 (J1)	±170°
	Axis 2 (J2)	-90~+165°
	Axis 3 (J3)	0~+165°
	Axis 4 (J4)	±190°
	Axis 5 (J5)	±120°
Maximum speed ^{*1}	Axis 6 (J6)	±360°
	Axis 1 (J1)	295°/s
	Axis 2 (J2)	270°/s
	Axis 3 (J3)	295°/s
	Axis 4 (J4)	422°/s
	Axis 5 (J5)	422°/s
Maximum payload mass ^{*1}		7.71m/sec
		4kg(rated:1kg) (Downward: 5kg)
Standard cycle time ^{*2}	0.4sec level	
Allowable moment of inertia	Axis 4, 5 ^{*1}	0.09kg·m ²
	Axis 6	0.1kg·m ²
Positioning repeatability ^{*3}	±0.03mm (X-Y-Z)	
Position detecting system	Absolute system/AC servo motor	
Power supply	1.5kVA	
Robot body	Mass	31kg
	color ^{*4}	White/blue

*1: Speed and acceleration are limited depending on motion patterns, payload mass, and offset value.
 *2: Continuous operation of standard cycle motion pattern is not possible beyond the effective load ratio.
 (Horizontal 300 mm, vertical 25 mm, round-trip, coarse positioning)
 *3: One way positioning repeatability when the environment temperature is constant at 20 degrees Celsius. Absolute position accuracy is not ensured.
 *4: Painting color may vary depending on the production lot. It does not affect the quality of the product.

[Features]

Special features

Tap holes

Tool fixture tap holes are provided at four locations on the arm, upper and lower positions. They are useful for fixing external cabling and peripheral devices.

Alternative installations

Tap holes on the side of the base unit allow for the robot to be installed sideways.

1st arm equipped with a T-groove as standard

The T-groove can be used to place tools, cabling and DIN rails in position.

Options

Robot controller cable options

In addition to the standard cabling at the back, cabling can be routed through the base.

This eliminates the need for installation space at the rear, and increases flexibility relating to the application and the space available.

I/O panel options

The I/O panel can be selected from three options.

An optional elbow type plug is available on the hand-side connection. (Option)

IP65 option

Dust-proof and drip-proof protection is available if required.

[External View]

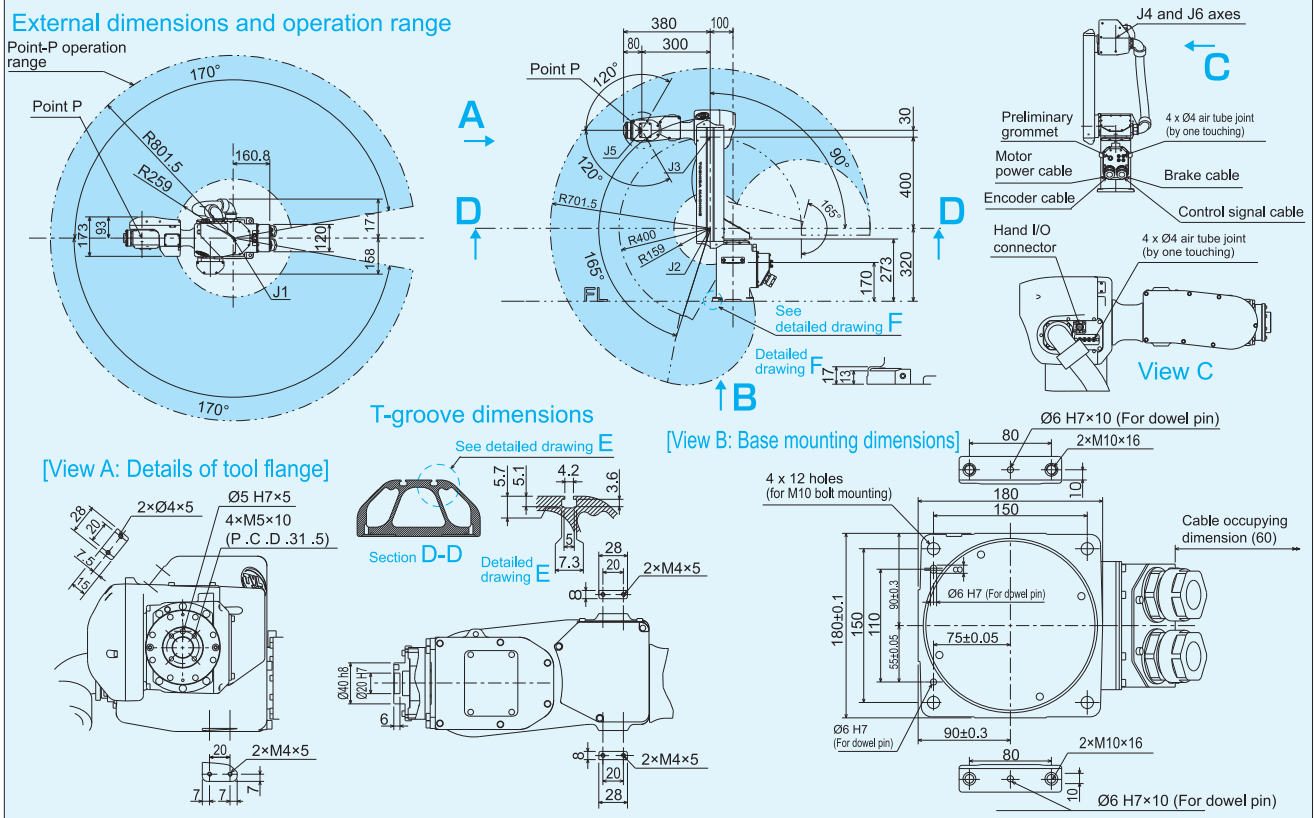

TOSHIBA MACHINE CO.,LTD. HEAD OFFICE
 Control Systems Sales Department, Control Systems Division
 2068-3, Ooka, Numazu-shi, Shizuoka-ken 410-8510, Japan
 TEL:[81-(0)55-926-5032 FAX:[81-(0)55-925-6527

TM ROBOTICS (AMERICAS) INC.
 755 Greenleaf Avenue, Elk Grove Village, IL 60007, U.S.A.
 TEL:[1]-847-709-7308 Mail:info@tmrobotics.com

TM ROBOTICS (EUROPE) LTD.
 Unit 2, Bridge Gate Centre, Martinfield,
 Welwyn Garden City, Herts AL7 1JG, UK
 TEL:[44-(0)1707-290370 Mail:nigel@tmrobotics.co.uk

URL:<http://www.toshiba-machine.co.jp/en/product/robot/index.html>
<http://www.toshiba-machine.com>
<http://www.tmrobotics.co.uk>
<http://www.tmrobotics.com>